

Questions
about car audio?

We Have
Answers.

Got more questions?
Call us toll free.



Bazooka® Mobile Audio
1-800-THE-TUBE
www.bazooka.com



2008 PRODUCT GUIDE



Q: "My car's radio just doesn't sound as good as my home stereo."

Mary T.: 28, Nurse, Memphis, TN.

A: That's because you need bass. Everybody needs bass, the question is, how much.

FOR EXAMPLE: If you were in your car listening to rock, rap, blues, country, or even classical, you would hear about 70% of the music that was recorded. The standard speakers in your car are not capable of reproducing bass. With the addition of a bass speaker, you get to experience that additional 30% of the music the artist intended for you to hear.

Another way to put it is, "The rhythm is in the bass!" The part of music that stirs people, gets their heart pumping, their emotions flowing and their feet tapping is the rhythm section. And, to experience the rhythm, you need bass.

**You Get
30% More
Music!!!**

EXPERIENCE MORE

Imagine your favorite band. Now imagine your favorite band without a drummer, bass player, or lead guitar. Bass lets you experience your music the way the band wanted you to hear it.

WHY BASS?



"The rhythm is in the BASS!"

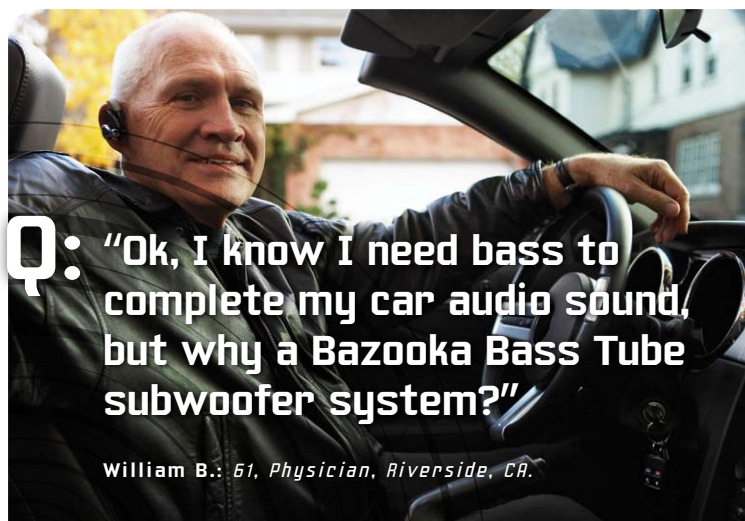

Q: "Ok, I know I need bass to complete my car audio sound, but why a Bazoooka Bass Tube subwoofer system?"

William B.: 61, Physician, Riverside, CA.

A: Like a rocket engine, canned drink, or your very own ear drum, a tube is a perfect pressure vessel, and bass is about pressure.

FOR EXAMPLE: The Bazoooka subwoofer's patented Bass Tubes bass-reflex enclosure design allows for use of 100% of the woofer's cone area. Inch for inch, Bass Tube enclosures will outperform most boxes.

BAZOOKA PERFORMANCE

Typical Box Design

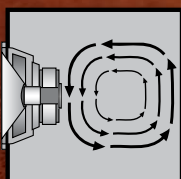

There are no corners for the bass to hide in!

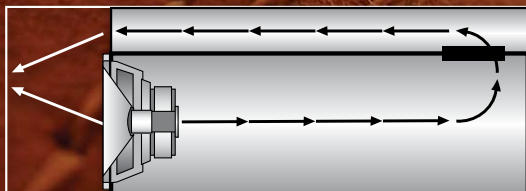

Bazoooka's Patented Bass Tube Enclosure Design

The Bazoooka® Bass Tubes enclosure is optimized for corner loading. The Bass Tubes enclosure's port and woofer are on the same plane and in close proximity for maximum corner-loading results. And, just like a megaphone amplifies a cheerleader's voice, the corner of your car amplifies the concentrated bass output of the Bass Tubes enclosure.

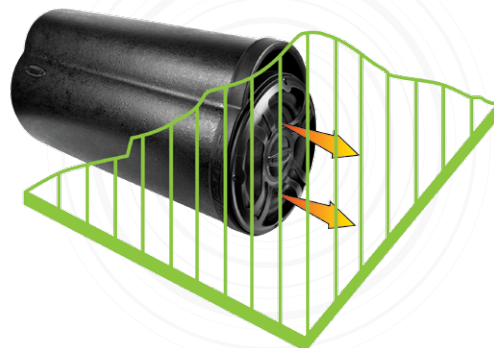

The Bass Tubes enclosure's advantage is it fits any vehicle. It's the perfect fit for a perfect sound.





Q: "Time is precious to me - how long will it take to install?"

Anna S.: 32, Homemaker, Sugarland, TX.

A: **F.A.S.T! (15-30 minutes)**

WHAT'S F.A.S.T?

F.A.S.T. is installing a Bazooka subwoofer in most cars in under 30 minutes. F.A.S.T. is getting your car sounding great quicker. F.A.S.T. is doing your install right the first time! F.A.S.T. is the innovative T-harness system that allows you to integrate the Bazooka subwoofer into the vast majority of factory sound systems out there. F.A.S.T. is the Factory Auto Sound T-Harness system.

FACTORY AUTO SOUND T-HARNNESS

WORRIED ABOUT INSTALLATION & INTERFACE ISSUES?

You don't have to be. With Bazooka®'s F.A.S.T. harnesses, installation is a breeze! Ideal for leased vehicles, or vehicles with difficult audio systems, the F.A.S.T. harness allows you to add bass to your system with a quick, plug and play installation. No cutting or splicing of factory wiring is necessary! Once you've got the correct interface cable for your car and the extension cable, simply plug in your amplified Bazooka® subwoofer. It's really that simple, and you'll know it's done right the first time, every time! (See Bazooka.com for compatible models)

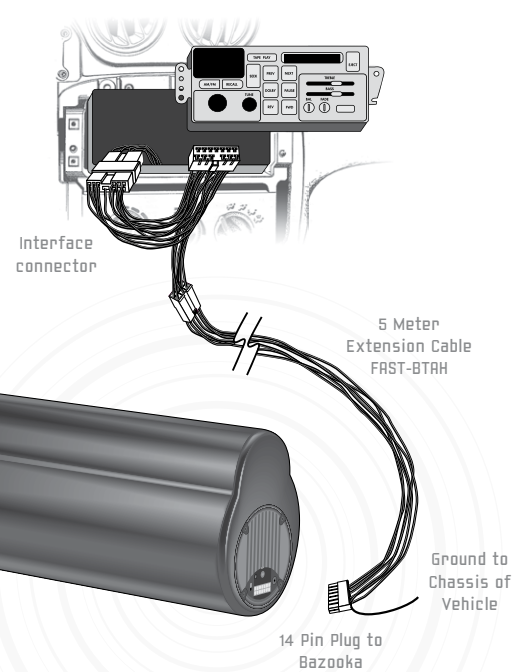
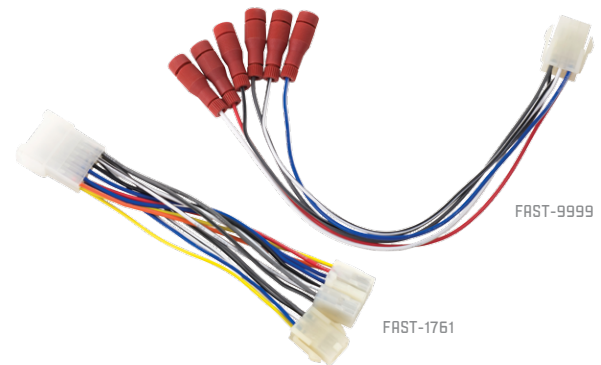

F.A.S.T. ACCESSORIES

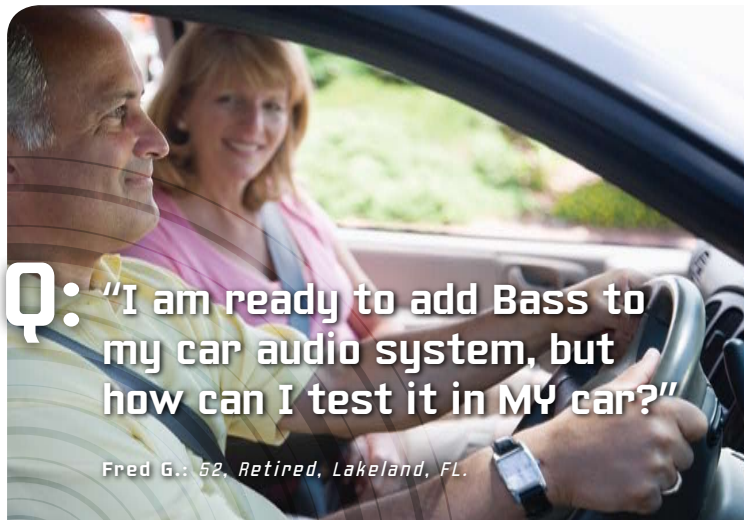

Q: "I am ready to add Bass to my car audio system, but how can I test it in MY car?"

Fred G.: 52, Retired, Lakeland, FL.

A: Find a retailer with our portable Bazooka subwoofer system!

In seconds, they will connect to your car's cigarette lighter and, using a small MP3 player, broadcast to your car's FM radio and the Bazooka subwoofer at the same time. Boom! Instant Bazooka Bass. Hear how good YOUR car can sound with YOUR music in just seconds!

TAKE A TEST DRIVE



The new amplified Bazooka® subwoofers feature the legendary patented Bass Tubes enclosure design, but with a twist. These units are completely self-contained bass monsters! Available in 100 watt BTL or 250 watt Class D amplifier configurations, the new amplified Bazooka subwoofers are the true solution to the common automobile interior problem of "not enough space for bass."



BTA6100



BTA62500



BTA8100



BTA82500



BTA10100



BTA102500

BT AMPLIFIED BASS TUBES

BT PASSIVE BASS TUBES

The non-amplified Bazooka® Subwoofers feature the legendary patented Bass Tubes® enclosure design and now incorporate the most advanced woofer design ever used in a Bazooka tube sub. The legend lives on in this latest revision of the most award-winning subwoofer in car audio history.



BT6014/6018



BT6024DVC/6028DVC



BT8014/8018



BT8024DVC/8028DVC



BT1014/1018



BT1024DVC/1028DVC

① THE BAZOOKA 12" PASSIVE BASS TUBE

The Pound-for-Pound, (Inch-for-Inch) Heavyweight Bass Champ



BT1214/
1224DVC

② THE DOUBLE ENDED AMPLIFIED BASS TUBE

TWO Tubes in ONE!



BTA8250D-DE
BTA10250D-DE

Introducing, for 2008, The Bazooka® Double-Ended 250W Class D 8" and 10" amplified subwoofer packages. Featuring our patented Bass Tubes enclosure design and our new 250W Class D integrated amplifier, these NEW dual 8" and dual 10" amplified tubes are a convenient "Drop-In" solution, for almost any vehicle. Whether you push them up against your rear seat, or put them in your trunk, you'll get DOUBLE the performance without double the cost or space in ONE convenient install!!

1-800-THE-TUBE | www.bazooka.com 10



Q: I've had my car for a while now. What do you have to upgrade my factory speakers.

Sean R.: 34, Investor, Atlanta, GA.

A: Our lineup of EL Coaxials are designed to deliver the absolute best value for upgrading your factory speakers.

EL COAXIALS

Available in all the common OEM replacement sizes, and sharing the heritage of the Legendary EL Coaxials, these speakers were designed for easy drop-in installation. All EL Coaxials feature poly-coated paper cones, mylar tweeters and built-in crossovers. With shallow mounting depths, and tweeters that will actually fit behind the stock grilles in your car, EL Coaxials are the PERFECT choice for upgrading your sound without drawing unnecessary attention to your audio system.

EL COAXIALS



ELC3502P



ELC4602P



ELC5702P



ELC4002P



ELC5252P



ELC6502P



ELC6903P



EL WOOFERS

We've refined the already spectacular lineup of EL woofers with PP reinforced paper cones, huge voice coils, rubber surrounds, foam edge gaskets, custom baskets, a large magnet with bumped backplate, and rear venting. And, like all other Bazooka woofers, the EL woofers are designed to utilize the optional Bazooka liquid cooling C.H.I.L. System, a quick way to get over 50% more RMS power handling. These woofers have proven to audiophiles around the world that a woofer doesn't have to have a big price tag to deliver big performance.



ELW1014P,
ELW1214P,
ELW1514P



Component Woofer Grille
GR-S10B, GR-S12B

The company that revolutionized the Amplified Subwoofer nearly 20 years ago is changing the way people party in their car again! With the new EL Party Packs, there's simply no easier way to get tons of bass in your trunk. Featuring hand selected components, specifically built enclosures, custom amplifier endplates, and custom stitching, these monsters are a perfect solution for those who want all the performance and custom look of a high end system, but would rather spend their time partying in the car instead of working on it. With Party Packs that range in size from the single 10 inch woofer with a 190 watt amplifier, to the MASSIVE dual 15 inch party pack with 500 watt amplifier, there's a Party Pack that's just right for you.



ELTVB10190PP



EL10190PP, EL12300PP,
EL15500PP

EL PARTY PACKS

EL AMPLIFIERS

In the past 4 years, no other amplifier lineup has presented more value, more power, and a better dollar-to-watt ratio than the EL Series Amplifiers. We've taken that a step further with an all new heatsink that allows for better cooling, and new circuitry that makes even more power in the same small, user-friendly footprint. Available as 2x65 watts, 4x65, 1x375, 1x500, and 1x800 watts, there's enough amplification here to power any system you can dream up!

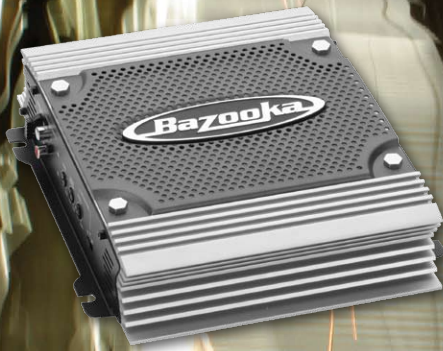

ELA265



ELA465, ELA1300, ELA1500, ELA1800

Without question, the Bazoooka® NOS Tube is the wildest and most original subwoofer enclosure design in the history of car audio. Use it alone, in pairs, or even mount it next to your existing Nitrous Oxide system. This 8" subwoofer is simply a Bazoooka® subwoofer with the patented Bass Tubes® enclosure camouflaged to look like a Nitrous bottle in Classic Blue to match the most popular Nitrous Oxide systems available. This unit comes complete with tank, cosmetic nozzle, braided line speaker wire and a mounting kit.

NOS TUBES



NOS8

MODEL NUMBER	BASIC PRODUCT DESCRIPTION	SPEAKER POWER HANDLING/ AMP MAX POWER	1W SENSITIVITY	FREQ.RESP. +/-3DB
AMPLIFIERS				
ELA265	2 x 65 watts @ 4ohm stereo, 2ohm mono capable	300 watts	N/A	25Hz-22kHz
ELA465	4 x 65 watts @ 4ohm stereo, 2ohm mono capable	600 watts	N/A	25Hz-22kHz
ELA1300	1 x 370 watts @ 2ohm mono (subwoofer amplifier only)	500 watts	N/A	25Hz-250Hz
ELA1500	1 x 500 watts @ 2ohm (subwoofer amplifier only)	750 watts	N/A	25Hz-250Hz
ELA1800	1 x 800 watts @ 2ohm (subwoofer amplifier only)	1000 watts	N/A	25Hz-250Hz
SUBWOOFERS				
ELW1014P	10" 4 ohm w/ Paper cone, rubber surround, 1.5" VC, CHIL compatible	300 watts	90 dB	20Hz-250Hz
ELW1214P	12" 4 ohm w/ Paper cone, rubber surround, 2" VC, CHIL compatible	400 watts	93 dB	20Hz-250Hz
ELW1514P	15" 4 ohm w/ Paper cone, rubber surround, 2.5" VC, CHIL compatible	500 watts	87 dB	20Hz-250Hz
SATELLITES				
ELC3502P	EL 2-way - 3.5" w/ Poly-paper woofer, mylar tweeter	50 watts	89 dB	85Hz-20kHz
ELC4002P	EL 2-way - 4" w/ Poly-paper woofer, mylar tweeter	50 watts	88 dB	85Hz-20kHz
ELC4602P	EL 2-way - 4" x 6" w/ Poly-paper woofer, mylar tweeter	50 watts	88 dB	75Hz-20kHz
ELC5252P	EL 2-way - 5.25" w/ Poly-paper woofer, mylar tweeter	75 watts	89 dB	5Hz-20kHz
ELC5702P	EL 2-way - 5" x 7" w/ Poly-paper woofer, mylar tweeter	75 watts	90 dB	65Hz-20kHz
ELC6502P	EL 2-way - 6.5" w/ Poly-paper woofer, mylar tweeter	100 watts	90 dB	65Hz-20kHz
ELC6903P	EL 3-way - 6" x 9" w/ Poly-paper woofer, mylar tweeter	100 watts	92 dB	55Hz-20kHz
TUBE SUBS				
BT6014	6.5" BAZOOKA tube subwoofer (8 OHM avail.)	100 Watts	100 dB	35Hz-250Hz
BT8014	8" BAZOOKA tube subwoofer (8 OHM avail.)	150 Watts	102 dB	35Hz-250Hz
BT1014	10" BAZOOKA tube subwoofer (8 OHM avail.)	200 Watts	104 dB	35Hz-250Hz
BT1214	12" BAZOOKA tube subwoofer	300 Watts	106 dB	35Hz-250Hz
BTA6100, 8100, 10100	6.5", 8" or 10" dual BTL amplified BAZOOKA tube subwoofer - 100 watt RMS	100 watts	N/A	35Hz-85Hz
BT6024DVC	6.5" BAZOOKA DVC tube subwoofer (8 OHM avail.)			
BT8024DVC	8" BAZOOKA DVC tube subwoofer (8 OHM avail.)	300 watts	102 dB	30Hz-250Hz
BT1024DVC	10" BAZOOKA DVC tube subwoofer (8 OHM avail.)	400watts	104 dB	30Hz-250Hz
BT1224DVC	12" BAZOOKA DVC tube subwoofer (8 OHM avail.)	600watts	106 dB	30Hz-250Hz
BTA6250D, 8250D, 10250D	6.5", 8" or 10" 250W Class D amplified BAZOOKA tube subwoofer - 250 watts RMS	250 watts	N/A	35Hz-250Hz
BTA8250D-DE, BTA10250D-DE	8" and 10" Double Ended 250W Class D amplified BAZOOKA tube subwoofer - 250 watts RMS	250 watts	N/A	35Hz-250Hz
NOS8	8" Bazooka subwoofer with Nitrous Bottle cosmetic finish	300 watts	102 dB	35Hz-250Hz
BOX SUBS/PARTY PACKS				
ELTV810190PP	Tri-vent enclosure, 1-ELW1012P 2 OHM woofer, 1-ELA1190 amplifier	300 watts	N/A	20Hz-250Hz
EL10190PP	Custom slot vented enclosure, 2-ELW1014P woofers, 1-ELA1190 amplifier	300 watts	N/A	20Hz-250Hz
EL12300PP	Custom slot vented enclosure, 2-ELW1214P woofers, 1-ELA1300 amplifier	500 watts	N/A	20Hz-250Hz
EL15500PP	Custom slot vented enclosure, 2-ELW1514P woofers, 1-ELA1500 amplifier	750 watts	N/A	20Hz-250Hz

© SAS, BAZOOKA, BASS TUBES, and LISTEN TO YOUR EARS are registered trademarks of the revolutionary BASS TUBES patented subwoofer enclosure design available only from SAS. Southern Audio Services, Inc. BAZOOKA subwoofer speaker systems exclusively incorporate PAT. NO. 4,567,959 • PAT. NO. 5,097,513. ©Southern Audio Services, Inc. All rights reserved.